



LD PLASTIC SOLUTION

www.ldplastic-solution.com



LD is one of the world's leading manufacturers of plastic injection mold. We have always been pushing development forward and set benchmark in automotive, high precision and 2k molds and others design areas.



World presence

America:

- Mexico
- Canada
- United States

Europe:

- Germany
- France
- Spain

Asia:

- Dongguan China





2006 / Start Company Factory in Taizhóu (Zhejiang)

2014 / Moved to a Factory in Shenzhen

2016 / Established a branch in Mexico

2018 / Established a Factory in Dongguan, specialized in mold

2019 / Established a Work Shop in Mamers, France

2020 / Established branch in Detroit, USA

2022 / Established Work Shop in Queretaro, Mexico



Future (5 Year plan): More People Investment, More Machines Investment, More Service investment



Our core capabilities include project management, designing, engineering, tooling and prototyping. Material selection has made that LD have a good performance in the molds industry.



Project Management Office

Designer and Engineering Office



Work Shop





We have worked projects with T2 & T1 companies for the following OEMs



TOYOTA



STELLANTIS



HONDA



JAGUAR



PEUGEOT



PORSCHE



TESLA

LD PLASTIC SOLUTION MEXICO

ASIA TEAM



L BUILDING , YANGWU VILLAGE , DALINGSHAN
TOWN DONGGUAN 523839, CHINA
Facility Space : 8,000 m²



Capacity:
960 molds per year
80 molds per month :
20 molds for 1600-3600 ton machine,
60 molds for middle to small size



STAFF

AREA	EMPLOYEES
Administration	4
Engineering [Projects / Programs]	12
Projects Management	6
Workshop [Processing & Assembly]	65



MOLD PRODUCTION EQUIPPMENT

ITEM	TABLE SIZE/MM	QTY/SET	REMARK
CNC	3100*2000*1000	2	5axis
CNC	3200*2100*1300	3	High speed
CNC	3200*2000*1350	1	High speed
CNC	2500*2000*1200	1	High speed
CNC	2500*1800*1000	1	High speed
CNC	2000*1000*900	1	High speed
CNC	1800*900*900	2	High speed
CNC	1650*800*900	1	High speed
CNC	1200*1000*900	1	High speed
EDM	1800*1600*1200	8	
EDM	1300*1200*1000	2	
EDM	800*650*600	3	
Fitting press	300ton	1	
Deep drilling		2	
Injection machines	80 to 470 Ton	6	For First Samples Only





SOFTWARE AVAILABLE: SIEMENS NX 12 / CATIA / MOLD FLOW

产品检测报告

睿诺科技(深圳)有限公司
Raynor Technology (Shenzhen) Co., Limited

Sample Inspection Report

Drawing

Item No.	Spec	Quantity	Material	Qty	Weight	Length	Width	Height	Area	Volume	Unit	Remarks
1	210-001	100	ABS	100	100.00	100.00	100.00	100.00	100.00	100.00	mm	
2	210-002	100	ABS	100	100.00	100.00	100.00	100.00	100.00	100.00	mm	
3	210-003	100	ABS	100	100.00	100.00	100.00	100.00	100.00	100.00	mm	
4	210-004	100	ABS	100	100.00	100.00	100.00	100.00	100.00	100.00	mm	
5	210-005	100	ABS	100	100.00	100.00	100.00	100.00	100.00	100.00	mm	
6	210-006	100	ABS	100	100.00	100.00	100.00	100.00	100.00	100.00	mm	
7	210-007	100	ABS	100	100.00	100.00	100.00	100.00	100.00	100.00	mm	
8	210-008	100	ABS	100	100.00	100.00	100.00	100.00	100.00	100.00	mm	
9	210-009	100	ABS	100	100.00	100.00	100.00	100.00	100.00	100.00	mm	
10	210-010	100	ABS	100	100.00	100.00	100.00	100.00	100.00	100.00	mm	
11	210-011	100	ABS	100	100.00	100.00	100.00	100.00	100.00	100.00	mm	
12	210-012	100	ABS	100	100.00	100.00	100.00	100.00	100.00	100.00	mm	
13	210-013	100	ABS	100	100.00	100.00	100.00	100.00	100.00	100.00	mm	
14	210-014	100	ABS	100	100.00	100.00	100.00	100.00	100.00	100.00	mm	
15	210-015	100	ABS	100	100.00	100.00	100.00	100.00	100.00	100.00	mm	
16	210-016	100	ABS	100	100.00	100.00	100.00	100.00	100.00	100.00	mm	
17	210-017	100	ABS	100	100.00	100.00	100.00	100.00	100.00	100.00	mm	
18	210-018	100	ABS	100	100.00	100.00	100.00	100.00	100.00	100.00	mm	
19	210-019	100	ABS	100	100.00	100.00	100.00	100.00	100.00	100.00	mm	
20	210-020	100	ABS	100	100.00	100.00	100.00	100.00	100.00	100.00	mm	
21	210-021	100	ABS	100	100.00	100.00	100.00	100.00	100.00	100.00	mm	
22	210-022	100	ABS	100	100.00	100.00	100.00	100.00	100.00	100.00	mm	
23	210-023	100	ABS	100	100.00	100.00	100.00	100.00	100.00	100.00	mm	
24	210-024	100	ABS	100	100.00	100.00	100.00	100.00	100.00	100.00	mm	
25	210-025	100	ABS	100	100.00	100.00	100.00	100.00	100.00	100.00	mm	
26	210-026	100	ABS	100	100.00	100.00	100.00	100.00	100.00	100.00	mm	
27	210-027	100	ABS	100	100.00	100.00	100.00	100.00	100.00	100.00	mm	
28	210-028	100	ABS	100	100.00	100.00	100.00	100.00	100.00	100.00	mm	
29	210-029	100	ABS	100	100.00	100.00	100.00	100.00	100.00	100.00	mm	
30	210-030	100	ABS	100	100.00	100.00	100.00	100.00	100.00	100.00	mm	

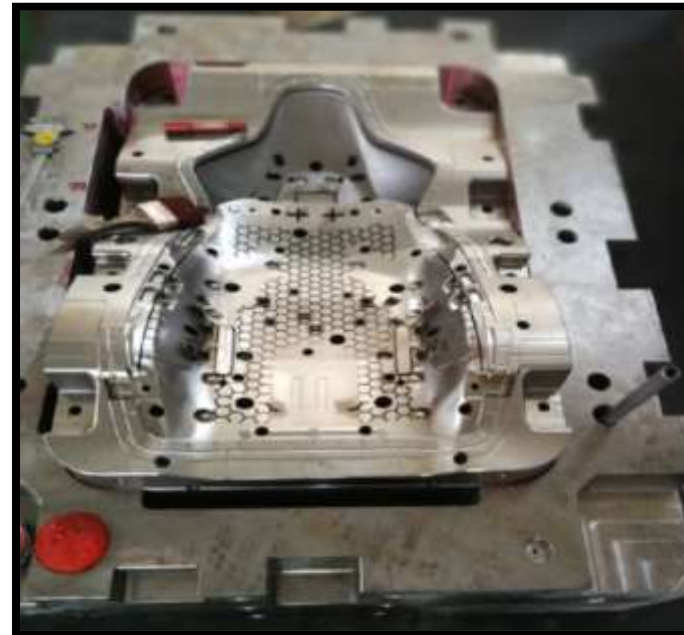
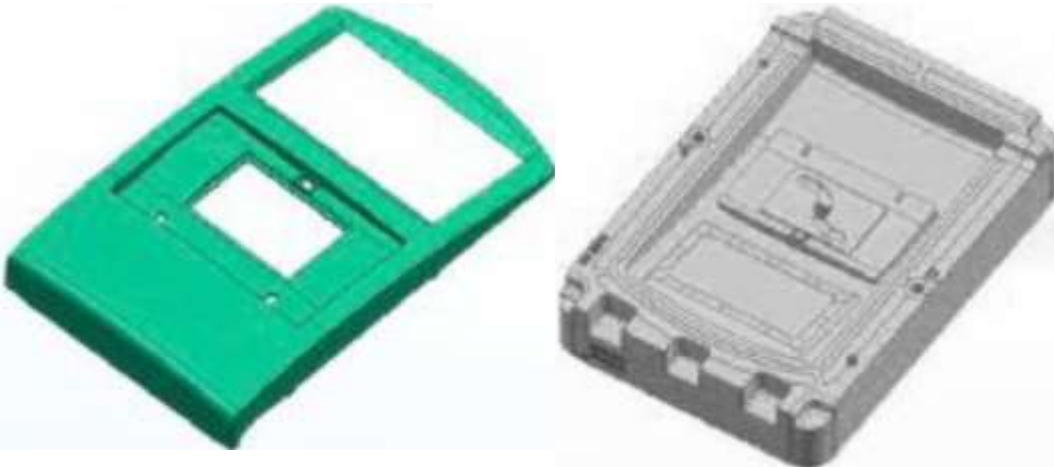
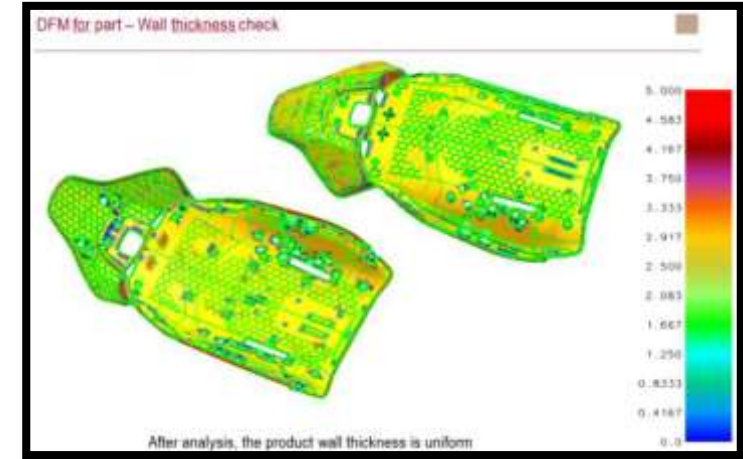



MOLD COMPONENTS SOURCE

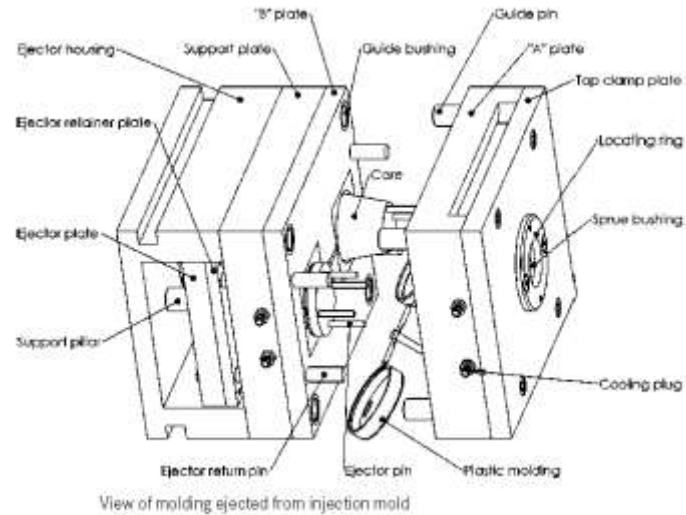

Steel & Mold Base					
Hot Runner					
Cylinder & Connector					
Standard Components	DME, HASCO, LKM, STRACK, CUMSA, STAUBLI, RABOURDIN, PROGRESSIVE, SLT, KR D, MISUMI, etc...				
Texture	Mold-Tech, YIXIN				

WE USE THE BEST STEELS, COMPONENTS, ACCESSORIES AND GRAINING APPLICATORS TO BUILD YOUR MOLDS



DIMENSIONAL TESTING LAB



CMM

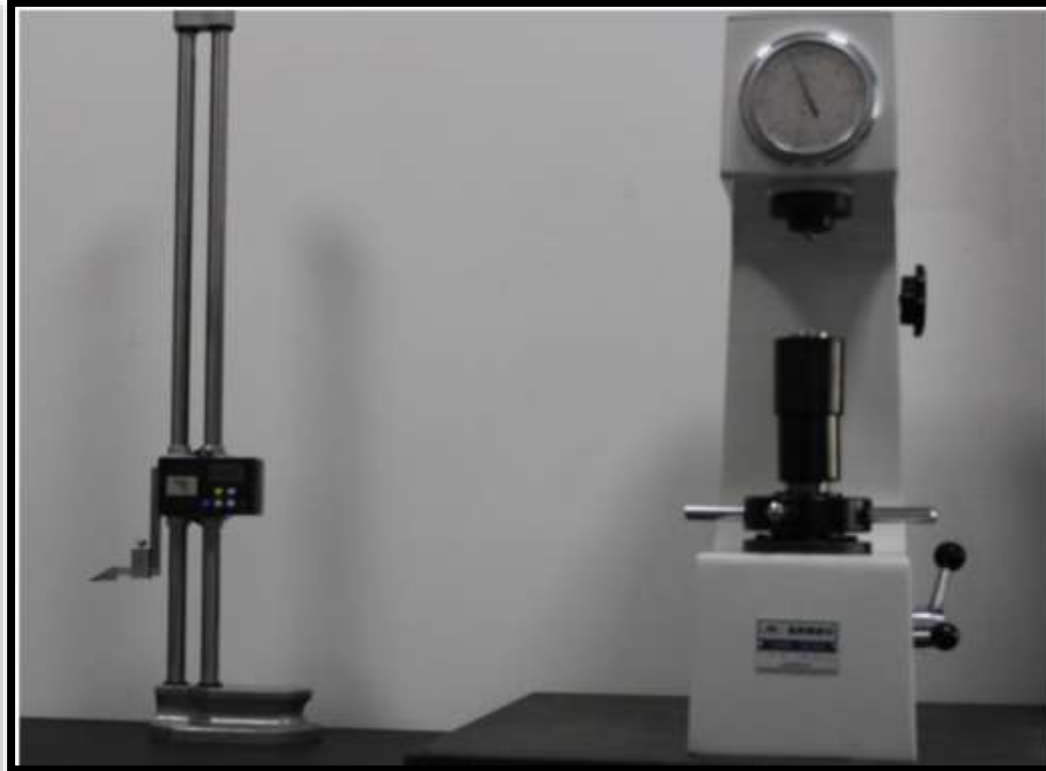

Measurement equipment

- Coordinate-Measuring Machine
- Optical Comparator
- Granite tables
- Height gauges, Calipers, etc.

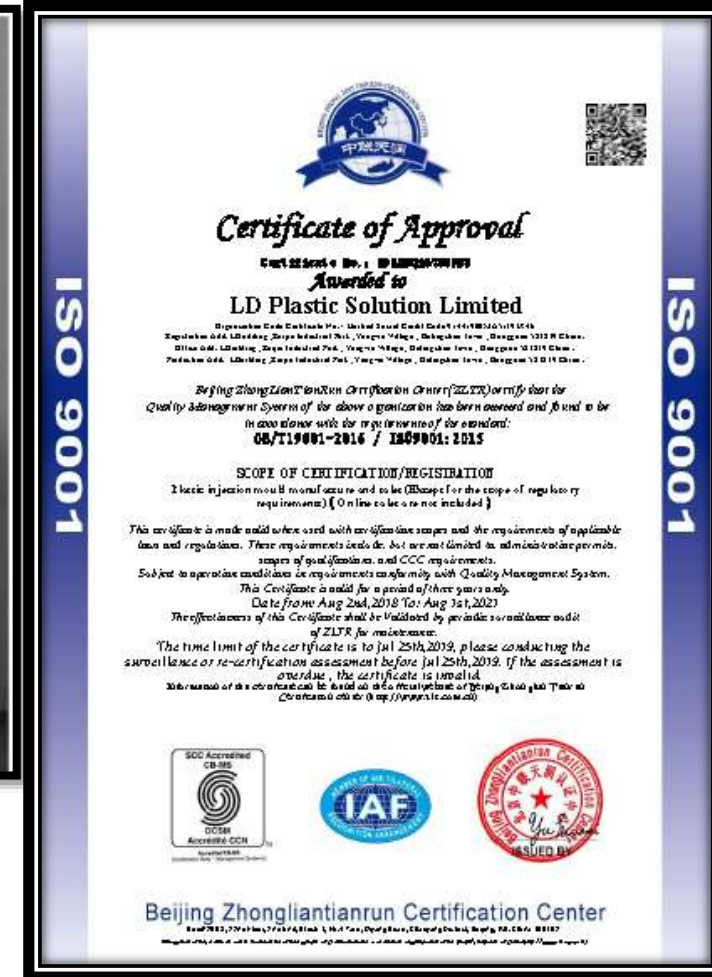

ISO 9001 Certificate



CHECKING FIXTURES





MOUNTING & ASSEMBLY FIXTURES





QUERETARO WORKSHOP

Technical Service & Workshop

Toolshop located in Parque Industrial Queretaro



Benito Juarez 113 A Parque Industrial Queretaro
76220 Queretaro, Mexico



DEVELOPMENT MANAGEMENT PROCESS

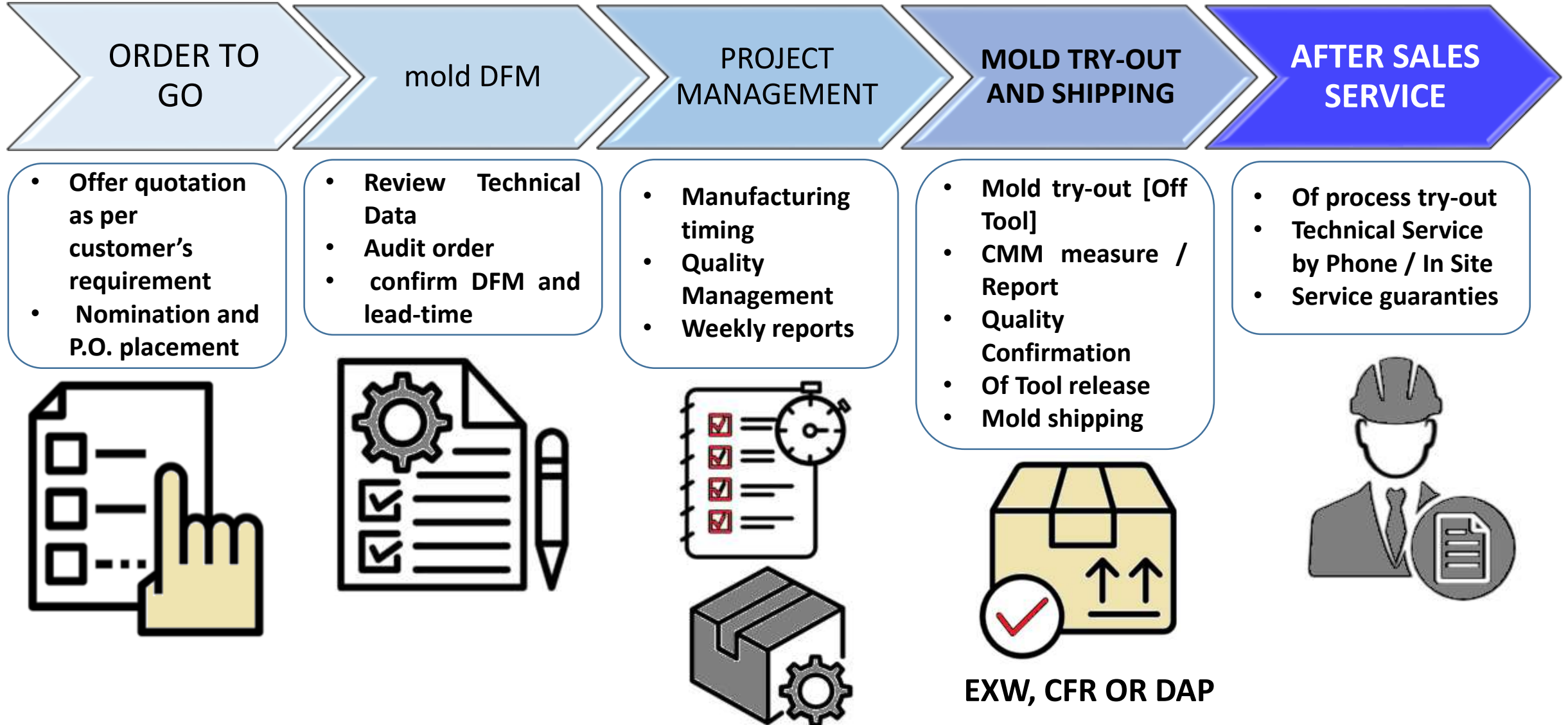

C:1440=120X12=(40:1.6kT-2.8kT+80M&s)

INTERIOR PARTS / COCKPIT MODULE

Door Panel



Make time :2014
Mold Weight :14T
Injection Machine: 1300T

Trunk Cover Inner



Make time :2016
Mold Weight :10T
Injection Machine: 1000T

INTERIOR PARTS / COCKPIT MODULE

Frame Cover for Central Console



Make time :2015
Mold Weight :8T
Injection Machine: 1000T

C:1440=120X12=(40:1.6kT-2.8kT+80M&s)

Frame cover for Entertainment Center
and Glove Box

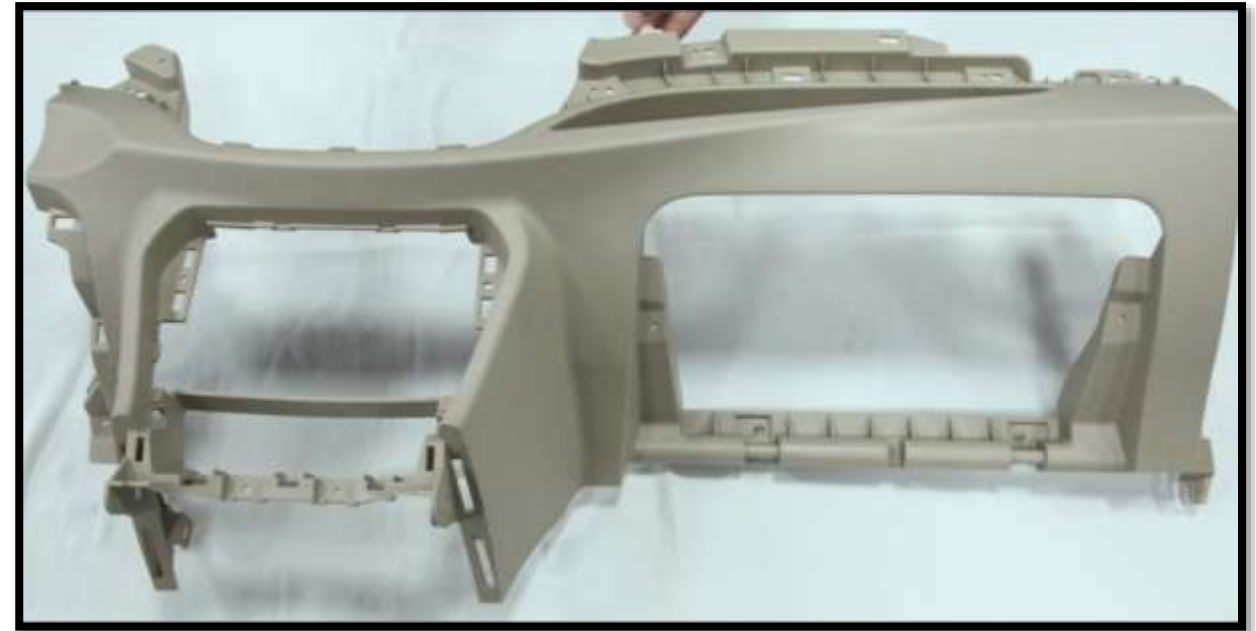

Make time :2016
Mold Weight :10T
Injection Machine: 1300T



THERMAL SYSTEMS MODULE

Water Boxes



Make time :2017
Mold Weight :3.5T
Injection Machine: 450T

Water tank



Make time :2014
Mold Weight :3T
Injection Machine: 450T

C:1440=120X12=(40:1.6kT-2.8kT+80M&s)

HVAC MODULES & DUCTS

Air Outlet



Make time :2016
Mold Weight :5T
Injection Machine: 600T



EXTERIORS MODULE

C:1440=120X12=(40:1.6kT-2.8kT+80M&s)

Bumper



Make time :2015
Mold Weight :32T
Injection Machine: 3000T

Foot Pedal



Make time :2016
Mold Weight :8T
Injection Machine: 1000T

Decorative Strips



Make time :2015 / 2016 / 2017
Mold Weight :1T - 5T
Cavities: 1+1
Injection Machine: 250T – 450T



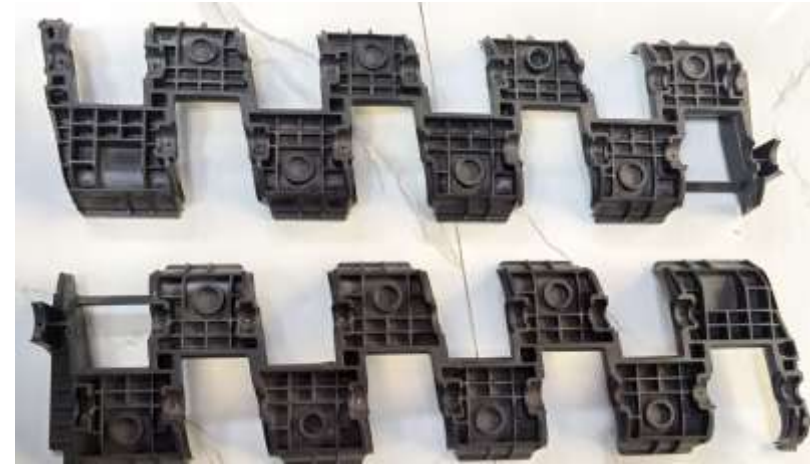

Large High Precision



Small High Precision

EXTERIORS MODULE

C:1440=120X12=(40:1.6kT-2.8kT+80M&s)

Framework Grille



Make time :2015
Mold Weight :12T
Injection Machine: 1300T

Front and Lower Grille



Make time :2016
Mold Weight :10T
Injection Machine: 1000T



EXTERIORS MODULE

Front Grille



Make time :2016 / Mold Weight :10T /
Injection Machine: 1000T

One Strip Front Grille



Make time :2016 / Mold Weight :8T /
Injection Machine: 1000T

C:1440=120X12=(40:1.6kT-2.8kT+80M&s)

Front Grille



Make time :2016 / Mold Weight :10T /
Injection Machine: 1000T

Two Strip Front Grille



Make time :2016 / Mold Weight :8T /
Injection Machine: 1000T



**WE CAN BE A GREAT TEAM
AND WORK TOGETHER TO MAKE YOUR TOOLING PROJECTS SAFE AND SUCCESSFUL**





Thank you for interest, we are waiting your valuable feedback...

Luther Wang

President

LD MOLD SOLUTION Mobile:

(86) 137.1501.7985

luther.wang@ldplastic-solution.com

Fernando Lopez

Country Manager Mexico

LD MOLD SOLUTION

Mobile: (52) 55.4331.3907

flopez@ldplastic-solution.com.mx

Roberto Lopez

Country Manager US

LD PLASTIC-SOLUTION

Mobile: 720.447.9915

roberto.lopez@ldplastic-solutions.com

Iván Miranda

Key Account Manager Mexico

LD MOLD SOLUTION

Mobile: (52) 442.187.3488

marketing@ldplastic-solution.com.mx

Nolberto Cortez

Northern Sales Manager Mexico

LD MOLD SOLUTION

Mobile: (52) 81.8033.7109

ncortez@ldplastic-solution.com.mx